



# WORKING ON ROOFS

INDG284



A man cleaning valley gutters on an asbestos cement sheet roof stumbled and fell to his death

Working on a roof can be dangerous. Falls account for more deaths and serious injuries in construction than anything else. Nearly half of them are from or through roofs and frequently involve fragile materials. Any fall from a roof inevitably involves at least serious injury. The risks are substantial however long or short the work. Many have been killed who only meant to be on the roof for a few minutes 'to have a quick look'.

This information sheet is aimed at people who actually carry out roof work or are directly responsible for managing or supervising it. It sets out key safeguards, but more detailed information is contained in *Health and safety in roof work* (order form at the back of this sheet).

Falls occur:

- from the edges of roofs;
- through gaps or holes in roofs;
- through fragile roof materials and roof lights.

In addition, many people have been seriously injured by material falling or thrown from roofs.

Accidents occur not only to those building roofs, but also to people maintaining, cleaning, demolishing and inspecting them.

Any work on a roof is high risk. High safety standards are essential however long or short term the work is. The nature of the precautions needed may vary from one job to another, but not providing any safeguards is simply unacceptable.

This information sheet sets out precautions that are relevant for all roof work and then describes precautions that are particularly relevant to different types of roof.

## PRECAUTIONS FOR ALL ROOF WORK

### Is the work necessary?

The best way to prevent a fall from or through a roof is to make sure nobody ever goes on or near it. Ask the question 'do we need to do the work?' For instance, if a roof is sound, is there any need to clean it for purely cosmetic reasons? If work does need to be done can it be done without going on the roof? For example, if the roof needs to be inspected can it be done by examination from a powered access platform?

### Risk assessment and method statements

A risk assessment should be carried out for **all** roof work. Simple jobs may not require a great deal. More complex ones need to be assessed in much more depth. But all roof work is dangerous and it is essential that the risks are identified before the work starts and that the necessary equipment, appropriate precautions and systems of work are provided and implemented.

Except for the simplest jobs where the necessary precautions are straightforward and can be easily repeated (eg use a proper roofing ladder to replace a ridge tile) safety method statements should be prepared. They should be specific and relevant to the job in hand and describe clearly the precautions and system of work identified during risk assessment. Diagrams or pictures can often say more

and be clearer than text. Everyone involved in the work needs to know what the method statement says and what they have to do. This might need someone to explain the statement for more complicated jobs. There will usually need to be some supervision during the work to check that the correct procedures are followed.

### Getting on and off the roof

Getting on and off the roof is a major risk. A secure means of entry and exit is essential. A properly secured ladder is the minimum requirement.

### Edge protection

Wherever anyone could fall more than 2 m, the first line of defence is to provide adequate edge protection. It needs to meet minimum legal standards of, or be equivalent to:

- a main guard rail at least 910 mm above the edge;
- a toe board at least 150 mm high;
- an intermediate guard rail or other barrier so that there is no gap more than 470 mm.

Sometimes a roof parapet may provide equivalent protection but if it does not, extra protection will be required.

### Work platforms

As well as edge protection it is just as important to provide an adequate and secure working platform. In many cases the roof itself will provide this. If it does not (eg when working on a chimney on a pitched roof) a platform should be provided.

### Fall arrest equipment

Providing adequate platforms and edge protection may not always be possible or reasonably practicable. If so either safety nets or harnesses will be required. They do not stop people falling, but minimise the potential injuries if they do.

If nets are used make sure that they are properly installed by competent riggers as close as possible below the roof involved to minimise the distance fallen. Installing a net **does not** mean that proper working platforms and edge protection can be ignored, because the first priority is to stop people falling in the first place.

If harnesses are used make sure that they are securely attached to a sufficiently strong anchorage point and that they are always worn. This requires user discipline and active management monitoring.

### Falling material

Keep a tidy site: stop material which could fall from accumulating.

Nothing should ever be thrown from a roof. Use enclosed rubbish chutes or lower material to the ground instead.

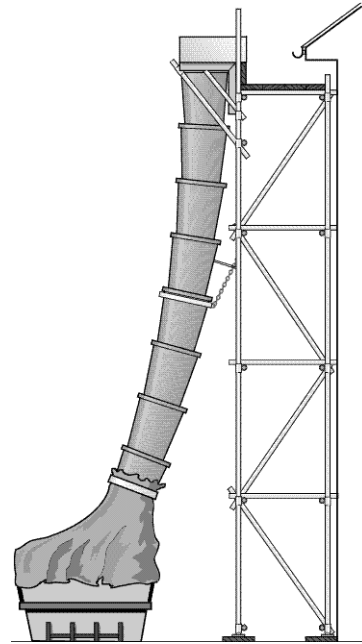

Rubbish chute and skip positioned to take waste materials

Prevent access to danger areas underneath or adjacent to roof work. Where this cannot be guaranteed, consider using debris netting, fans, covered walkways or similar safeguards to stop falling material causing injury.

Particular care is needed where there is public access close to roof work. If possible try to arrange for work to be carried out when passers-by will not be there, eg carry out repairs to schools during the school holidays. If this cannot be arranged minimise the public access to danger areas. In some cases physical protection to catch falling materials, eg fans, may be appropriate. Remember that even fine material such as dusts can cause discomfort or injury to eyes.

### Training

Roof workers need the appropriate knowledge, skills and experience to work safely, or be under the supervision of someone else who has it.

They need to be able to recognise the risks, understand the appropriate systems of work and be competent in the skills to carry them out such as:

- installing and wearing harness systems;
- installing edge protection;
- operating a mobile access platform.

Training will usually be required to achieve these competencies. It is not sufficient to hope that workers will 'pick up safety on the job'.

### Weather conditions

Do not work on roofs in icy, rainy or windy conditions. Anyone carrying a roof sheet can easily be blown off the roof if they are caught by a gust of wind.

Avoid excessive exposure to sunlight by wearing appropriate clothing and using suncreams. Too much exposure to sunlight can cause skin cancer.

### Short-Duration Work

Short-duration work means that lasting minutes rather than hours. It may not be reasonably practicable to provide full edge protection for short-duration work but it still needs to be considered during assessment and should not be automatically discounted.

Mobile access equipment can provide both edge protection and a working platform. It can do away with the need for scaffolding and can be particularly appropriate for short-duration minor work.

Where it is not reasonably practicable to provide full edge protection, a securely attached safety harness will normally be required (see 'Short-duration work on sloping roofs').

## FRAGILE ROOFS

### What is fragile?

A fragile material is one that does not safely support the weight of a person and any load they are carrying. The fragility of a roof does **not** depend solely on the composition of the material in it. The following factors are also important:

- thickness of the material;
- the span between supports;
- sheet profile;
- the type, number, position and quality of fixings;
- the design of the supporting structure, eg the purlins;
- the age of the material.

Sometimes the entire roof surface is fragile, such as many fibre cement roofs. Sometimes part of the roof is fragile, eg when fragile roof lights are contained in an otherwise non-fragile roof. Sometimes a roof is temporarily fragile, such as during 'built up' roof construction when only the liner is installed or sheets have not been secured. Sometimes the fragility of a roof can be disguised, for instance when old roofs have been painted over. This guidance applies to all these situations.

The fragility, or otherwise, of a roof should be confirmed **before** work starts. If there is any doubt, the roof should be treated as fragile unless, or until, confirmed that it is not. It is positively dangerous to assume that a roof is non-fragile without checking this out beforehand.

### Prevent unauthorised access

Make sure that unauthorised access to the roof is prevented by, for instance, implementing a permit-to-

work regime or blocking off roof access ladders. Make sure that appropriate warning signs are displayed on existing roofs, particularly at roof access points.

### Working on fragile materials

At **no** time may anyone work on, from or pass over fragile material, unless platforms, coverings or other similar means are provided that adequately support them. Properly installed safety netting beneath the roof surface will provide collective fall protection within the protected area. Harnesses can also be an effective solution, but if used they require adequate attachment points which may be difficult to arrange in work on fragile roofs. They also rely on user discipline, training and constant supervision to ensure that they are consistently and correctly used.

Support platforms should be at least 600 mm wide and more when the work requires it.

Make sure that support platforms are long enough to provide adequate support across roof members. They should span across at least two purlins. Using a platform may spread the load, but that will not provide enough support if the only thing supporting it is the fragile material.

Walking on the lines of purlin bolts gives no protection whatsoever. It is like walking a tightrope and must never be allowed or condoned.

Workers should not have to constantly move platforms about the roof. It is not acceptable to rely on using a pair of boards to 'leap-frog' across a fragile roof. Make sure there are enough platforms provided to avoid this.

Precautions are needed to prevent a person falling from the platform. If possible provide the platform with edge protection comprising top rail, intermediate rail (or equivalent protection) and toe board.

### Working near fragile material

Protection is needed when anyone passes by or works nearer than 2 m to fragile materials, eg:

- during access along valley gutters in a fragile roof;
- when fragile roof lights or smoke vents are contained in an otherwise non-fragile roof;
- during access to working areas on a fragile roof.

Wherever possible make sure that all fragile materials, 2 m or closer to the people at risk, are securely covered. Alternatively, provide full edge protection (ie top rail, intermediate guard rail or equivalent and toe board) around or along the fragile material to prevent access to it. (Make sure that appropriate precautions are taken when installing such protection, eg the use of netting or safety harnesses.)

Sometimes it will not be reasonably practicable to provide such protection, usually if the proximity to fragile material is irregular and short duration, ie a matter of

minutes. Safety harnesses will usually be the appropriate solution and may be used in conjunction with any permanently installed running line systems.

Boundaries can be established identifying 'safe' areas containing the workplace and routes to and from it. If these are used:

- the boundary should be at least 2 m from the nearest fragile material;
- the boundary does not need to comply with full edge protection standards, but there should be a physical barrier (a painted line or bunting is not acceptable);
- tight discipline is essential to ensure everyone stays inside the safe area at **all** times.

### WORKING ON SLOPING ROOFS

On traditional pitched roofs most people fall:

- from eaves;
- by slipping down the roof and then over the eaves;
- through the roof internally, eg during roof truss erection;
- from gable ends.

### Edge protection

Full edge protection at eaves level will normally be required for work on sloping roofs. The edge protection needs to be strong enough to withstand a person falling against it. The longer the slope and the steeper the pitch

the stronger the edge protection needs to be. A properly designed and installed independent scaffold platform at eaves level will usually be enough. Less substantial scaffolding barriers (rather than platforms) may not be strong enough for work on larger or steeper roofs, especially slopes in excess of 30°.

On some larger roofs, the consequences of sliding down the whole roof and hitting the eaves edge protection may be such that intermediate platforms at the work site are needed to prevent this happening.

If the work requires access within 2 m of gable ends, edge protection will be needed there as well as at the eaves.

Powered access platforms can provide good access as an alternative to fixed edge protection. They can be particularly useful in short-duration work (see 'Short-duration work on sloping roofs') and during demolition when gaps are created in the roof.

### Roof ladders

Slates and tiles do not provide a safe footing especially when they are wet. Properly designed roof ladders or crawling boards are an essential aid to any work on sloping roofs. They should be long enough to span the supports (at least three rafters) and securely placed. Roof ladder anchorages should bear on the opposite roof and not rely on the ridge tiles for support as these can easily break away. Do not use gutters to support any ladder.

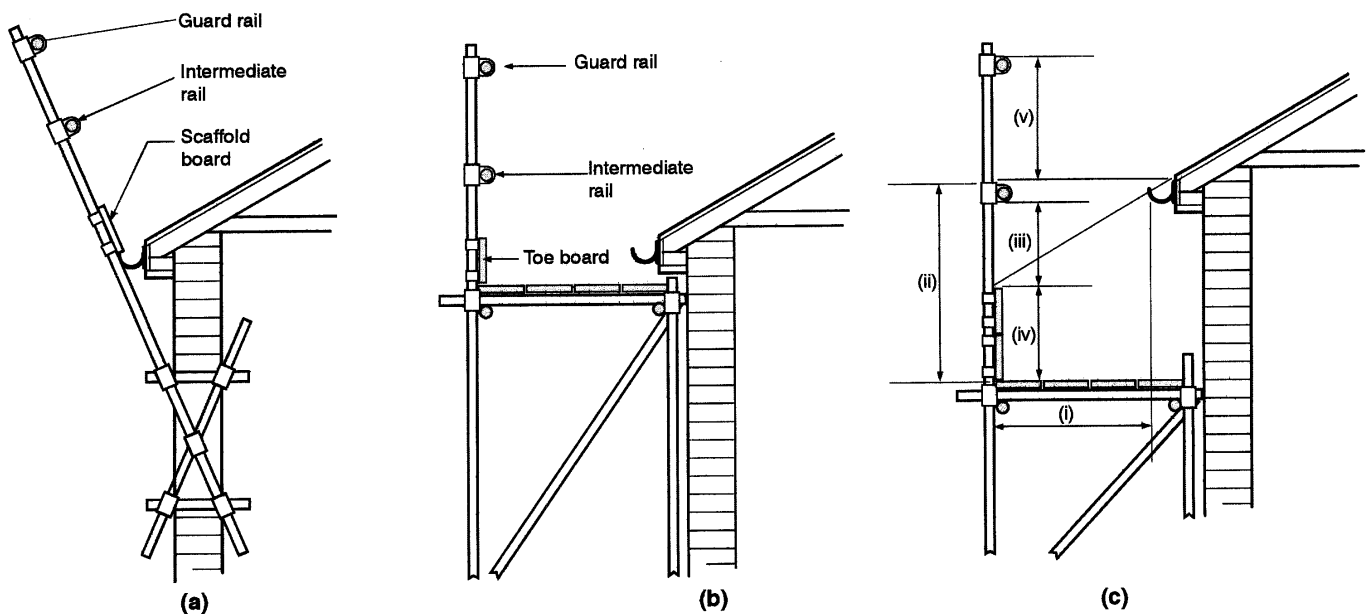

Sloping roof edge protection; typical arrangement in conventional tube and fittings

- (a) Supported from window opening
- (b) Working platform below the eaves
- (c) Top lift of a scaffold. Dimensions should be as follows:
  - (i) Working platform minimum width 600 mm
  - (ii) Minimum 910 mm
  - (iii) Maximum gap 470 mm
  - (iv) To rise to the line of the roof slope with a minimum height of 150 mm
  - (v) Gap between rails no more than 470 mm

Typical sloping roof edge protection. Barriers shown in (a) can be useful where space is limited, but they are not capable of sustaining loads so large as (b) and (c) which also provide a working platform.

Roof battens can be an alternative to roof ladders but if relied on it is essential that their strength is established beforehand. Battens often fail. (They should be attached to rafters no more than 450 mm apart if used as footing.)

### Short-duration work on sloping roofs

Short-duration work means tasks that are measured in minutes rather than hours. It includes such jobs as replacing a few tiles or adjusting a television aerial. **Work on a roof is still dangerous even if it only lasts a short time. Appropriate safety measures are essential.**

For short-duration work it may not be reasonably practicable to provide full edge protection (but if it is it should be provided). This does not mean that nothing needs to be provided in its place. The minimum requirements for short-duration work on a roof are:

- a safe means of access to roof level;
- a properly constructed and supported roof ladder.

Roof workers should not work directly on tiles or slates.

### Erecting roof trusses

If possible, reduce the need for work at height by assembling roof sections on the ground and craning them into position.



Roof truss built on ground and lifted into position avoiding the need to work over open joisting later on

If trusses are assembled *in situ*, provide a safe working platform, preferably by boarding out the area as close as possible to the underside of the trusses, or alternatively supporting a platform on the truss members. If a separate platform is used, make sure it can safely support the worker and has edge protection. The truss

members may provide adequate edge protection but not always.

If possible, an adequate working platform should be provided which protects against falls during roof truss erection. If a platform does not provide complete protection then safety nets can be provided as well to catch anyone who falls.

### INDUSTRIAL ROOFING

Building and working on steel framed wide-span industrial roofs involves a number of hazards, such as falls:

- from the roof edge;
- through gaps in the partially completed roof;
- through liner panels;
- from the leading edge when unprotected gaps are inevitable;
- from the frame, eg when loading out with roof sheets.

These hazards can all arise not only at the working position but also the routes to and from it.

### Systems of work

Good planning can significantly reduce the risks involved in industrial roofing. Key elements are as follows.

1 Reduce the need for workers to travel about the roof by:

- arranging for the right sheets to be delivered as they are needed to the right place at the right time;
- arranging access points that are convenient for the working position;
- making full use of loading bays.

2 Minimise the potential for falls by providing a safe place of work (eg properly guarded working platforms or powered access equipment) rather than relying on fall arrest equipment to restrict a fall.

### Falls from the roof edge

Full edge protection (comprising top rail, toe board and intermediate protection) is required whenever the work requires access within 2 m of the roof perimeter.

### Falls through gaps

If work involves any likelihood of access within 2 m of such gaps they should be covered. If this is not possible provide edge protection or as a last resort install safety netting beneath the gap.

### Falls through liner panels

Liner panels on their own should be considered as fragile unless it has been conclusively confirmed that they are not. Try to avoid 'lining out' the shell to

weatherproof the site. This will avoid the need for a second pass at height as well as the presence of a large expanse of potentially fragile material. Consider the use of composite panels to reduce the need for work at height.

### Falls from the leading edge

Whatever system of work is chosen the presence of dangerous gaps is always a possibility as space is created to place the next leading edge sheet. Options to deal with this include:

- temporary barriers at the leading edge, such as trolley systems;
- birdcage scaffolds;
- safety nets;
- safety harnesses used with running line systems.

Safety nets are the least problematic and hence the preferred option. Trolley systems can be a useful aid, but are not appropriate for all roofs, eg where there are hips or dormers. Remember that installing and moving such systems can involve significant risks. Where trolley systems are used, make sure that:

- there is a safe system of work for installing and dismantling them;
- the trolley system is compatible with the purlin design;
- there is a safe system of work for moving the trolleys;
- the trolley can move freely - if it jams it can be dangerous trying to release it;
- there is safe access to the trolley;
- the trolley is locked in position so that it does not overturn if someone falls onto it;
- there is a suitable barrier at the trolley end if someone could fall from it.

If trolley systems are used, the system of work needs to be carefully thought out to avoid unnecessary risks, eg can roof workers lock the trolley in position after it has been moved forward without stepping over the newly created gap?

Make sure that either safety nets or harnesses are used to protect against falls through the gaps created as the leading edge moves forward.

If safety nets are used make sure that they:

- are installed as close as possible beneath the roof surface;
- are securely attached and will withstand a person falling onto them;
- are installed and maintained by competent personnel.

If harnesses are used make sure that they:

- are securely attached to an adequate anchorage point (trolley guard rails are not usually strong enough);
- are appropriate for the user and in good condition;



Safety nets installed prior to sheeting. Note the net is fixed as close to the underside of the roof as possible to minimise the extent of any fall

- are actually and properly used - ensuring this requires tight discipline.

Safety netting is the preferred fall arrest option since it provides collective protection and does not rely on individual user discipline to guarantee acceptable safety standards. They can simplify systems of work and can protect not only roof workers, but others such as supervisors.

### Falling Materials

Try to avoid leaving materials on the roof when the site is closed especially at weekends and during holiday periods. If materials are left on the roof make sure that they are secured so that they cannot be blown off the roof by windy weather.

Make sure that toe boards are in place around the roof perimeter.

Control other trades' access to areas underneath roofing work, unless protection such as debris netting is provided which **ensures** protection for anyone working underneath.

### Manual handling

Handling awkward roof sheets is a particular problem for roof workers and can lead to back injuries which can cause a lifetime of pain and disability.

Minimise the need for manual handling by using mechanical handling devices, eg hoists, to deliver materials where they are actually needed on the roof. Where manual handling cannot be avoided arrange systems which make manual handling easier. Provide workers with information about the weight of the loads they will have to carry.

## WORKING ON FLAT ROOFS

Work on a flat roof is high risk. People can fall:

- from the edge of a completed roof;
- from the edge where work is being carried out; through openings or gaps.

### Edge protection

Unless the roof parapet provides equivalent safety, temporary edge protection will be required during most work on flat roofs. Both the roof edge and any openings in it need to be protected. It will often be more appropriate to securely cover openings rather than put edge protection around them. Any protection should be:

- in place from start to finish of the work;
- strong enough to withstand people and materials falling against it.

Where possible the edge protection should be supported at ground level, eg by scaffold standards, so that there is no obstruction on the roof. If the building is too high for this, the roof edge upstand can support the edge protection provided it is strong enough. Edge protection can also be supported by frames, counterweights or scaffolding on the roof. The protection should be in place at all times. Guarding systems are widely available that enable roof repair work to carry on without removing any guard rails.

### Demarcating safe areas

Full edge protection may not be necessary if limited work on a larger roof involves nobody going any closer than 2 m to an open edge. In such cases demarcated areas can be set up, outside which nobody goes during the work or access to it. Demarcated areas should be:

- limited to areas from which nobody can fall;
- indicated by an obvious physical barrier (full edge protection is not necessary but a painted line or bunting is not sufficient);
- subject to tight supervision to make sure that nobody strays outside them (demarcation areas are unacceptable if this standard is not achieved).

### Short-duration work on flat roofs

Short-duration means a matter of minutes rather than hours. It includes such jobs as brief inspections or adjusting a television aerial. **Work on a flat roof is still dangerous even if it only lasts a short time. Appropriate safety measures are essential.**

It may not be reasonably practicable to provide edge protection during short-duration work. In such cases anyone working nearer than 2 m to any unguarded edge should be using a safety harness. Where safety harnesses are used they need to be:

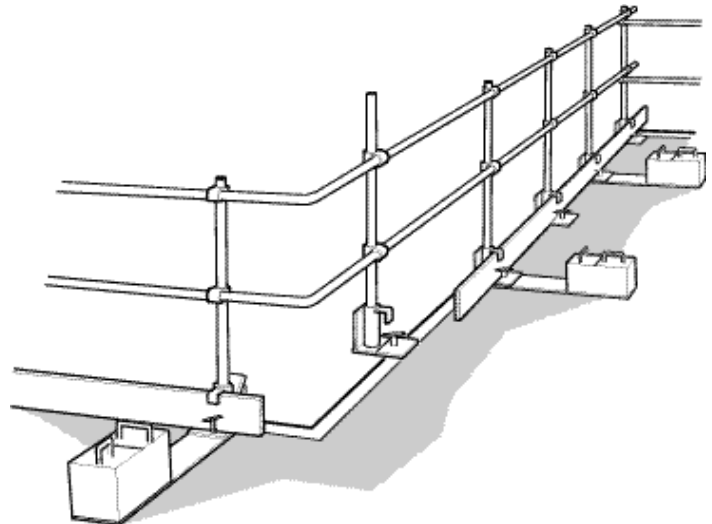

Counterweight removed and baseplate lifted for work near edge

- appropriate for the user and in good condition - full harnesses are essential, safety belts are not sufficient;
- securely attached to an anchorage point of sufficient strength;
- fitted with as short a lanyard as possible that enables wearers to do their work;
- actually used - tight management discipline is needed to ensure this.

### Further reading

More detailed information is contained in:

*A guide to the Construction (Health, Safety and Welfare) Regulations 1996* INDG220 HSE Books 1996

*Health and safety in roof work* HSG33 (Second edition) HSE Books 1998 ISBN 0 7176 1425 5

*Health and safety in construction* HSG150 (Second edition) HSE Books 2001 ISBN 0 7176 2106 5

The future availability and accuracy of the references listed in this publication cannot be guaranteed.

HSE priced and free publications are available by mail order from HSE Books, PO Box 1999, Sudbury, Suffolk CO10 2WA Tel: 01787 881165 Fax: 01787 313995 Website: [www.hsebooks.co.uk](http://www.hsebooks.co.uk) (HSE priced publications are also available from bookshops.)

For information about health and safety ring HSE's InfoLine Tel: 08701 545500 Fax: 02920 859260 e-mail: [hseinformationservices@natbrit.com](mailto:hseinformationservices@natbrit.com) or write to HSE Information Services, Caerphilly Business Park, Caerphilly CF83 3GG. You can also visit HSE's website: [www.hse.gov.uk](http://www.hse.gov.uk)

This leaflet contains notes on good practice which are not compulsory but which you may find helpful in considering what you need to do.

This publication may be freely reproduced, except for advertising, endorsement or commercial purposes. First published 5/99. Please acknowledge the source as HSE.