

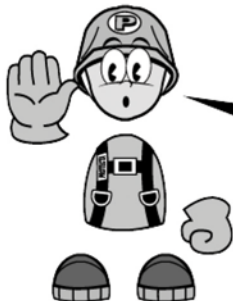

CABLOG

by PROTECTA

Vertical Life Line



Warning :
Read carefully those instruction
to respect manufacturer
recomendations for mounting

F

KIT AC3000

Vertical Lifeline

Technical file
Installation manual

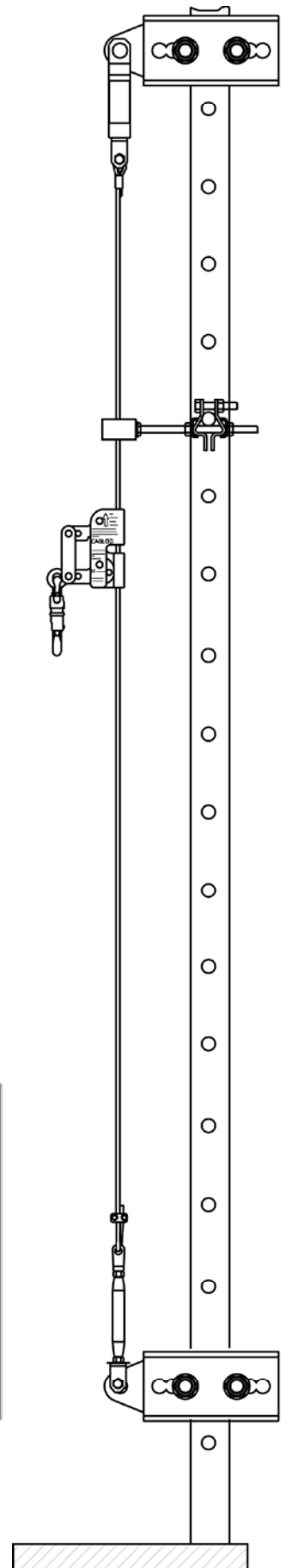

CABLOC TECHNICAL FILE

Vertical safety line

Technical file - Installation procedure

Contents

1 Caution	p 02
1.1 CABLOC	p 03
2 Technical file	p 03
2.1 General principle	p 03
2.2 Product description	p 03
2.3 Parts list	p 04
3. Installation procedure	p 05
3.1 Installation procedure	p 05
3.2 Particular clauses	p 05
3.3 Anchorage boom attachment	p 06
3.4 Installation of energy dissipator	p 06
3.5 Installation of cable	p 06
3.6 Installation of cable guides.	p 06
3.7 Installation of tensioner	p 07
3.8 Signaling	p 07
3.9 Lead sealing	p 08
4 Use	p 08
5 Maintenance	p 08
6 Limited Lifetime Warranty Statement	p 08
CABLOC test sheets	p 09

1 CAUTION

All the parts referenced below have been tested and meet the requirements of standard EN 353 class 1 or EN353 class 2. All these parts are of stainless steel and are guaranteed against any manufacturing defects by Capital Safety Group.

The CABLOC safety line can be installed on concrete supports rated at 25 Mpa or on metal structures. In both cases, the installer must ensure the mechanical strength of the receiving structure by a calculation design note produced by a qualified person. He must then ensure the compatibility of the components on the line with this design note.

The CABLOC safety line must only be installed with the components recommended by Capital Safety Group. Without the prior written agreement of Capital Safety Group, it is strictly prohibited to change, modify, add or convert components in the safety line.

The liability of Capital Safety Group is confined to the supply of the equipment. Capital Safety Group declines any responsibility for the installation of the CABLOC lifeline. To eliminate all risks, it is mandatory to comply stringently with the installation procedure supplied with the CABLOC lifeline.

1.1 CABLOC

You have just purchased a CABLOC safety line.

This line consists of variable components which must be installed in accordance with the instruction manual.

Installation of a CABLOC safety line conforming to standard EN 353/1 and AS/NZS 1891.2.

In conformance with the requirements of the GUIDED TYPE FALL ARRESTER SYSTEM ON A RIGID ANCHORAGE LINE standard, the installation of the anchorage line must be secured to the structure so that the lateral movements on the line are limited. Accordingly, it will be necessary to attach the two ends of the system to the structure.

The system is equipped with: an energy absorber for use at the line head.

2 TECHNICAL FILE

2.1 General principle

2.11 - USE

- vertical
- 1 user
- Recommended distance between two anchorage points: **10 m** (from one end to a cable guide part or between two cable guides)
- Connection of user to line by a CABLOC AC 350 or AC350/4 fall arrester.
- Absorber AC 325 to be used according to the selected fall arrester (see 1.1).

2.12 – END ANCHORAGE EN795/A

- Minimum support strength: **10 kN** (A single person anchorage point in AS/NZS 1891.4 is required to support a load of 15kN)
- Assembly on all types of supports

2.13 – CABLE GUIDE

- Assembly on all types of supports

2.14 - CABLE

- Stainless steel \varnothing 8 mm 7X19
- Breaking strength > **36.5 kN**
- Pretensioning 0.8kN

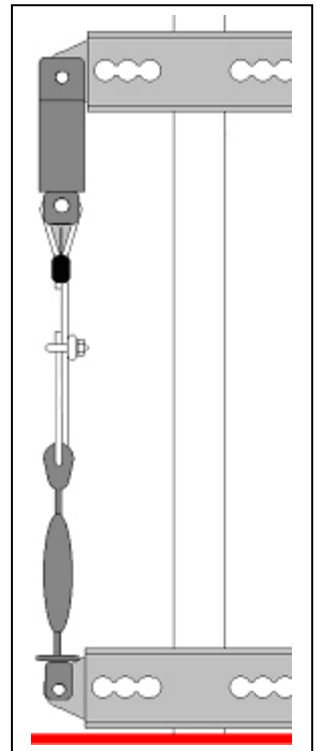

2.2 Description of Product

2.21 - PRESENTATION

Fall arrester allowing a person to ascend and descend safely in a vertical plane without having to detach.

2.22 - REFERENCE TO STANDARDS

The EN 353/1 and EN 353/2 standards concerning fall arrest devices were published on 20 Apr 1993 to enter into effect on 20 May 1993. Consequently, the product complies completely with the requirements of AS/NZS 1891.2. The CABLOC safety line is designed, produced and tested according to the requirements of these standards. The APAVE inspection organization carried out the testing and supplied the following test reports:

CABLOC ref AC350

No 0082/37/160/03/95/0055

EN353/1 stainless steel cable 8 mm 7X19

2.23 – COMPONENT QUALITY

All the components forming the safety line are of stainless steel. The hardware material is ISOA4 stainless steel.

The \varnothing 8 mm 7X19 metal core cable is of stainless steel

The cable is delivered cut to length in the factory, fitted with a thimble eye and swaged.

The crimping of the tensioner at the bottom end is carried out on-site by fitting an olive crimping device or a cable clamp.

2.3 Parts list

2.31 CABLOC fall arrester ref AC350

With a slide mounted on a rigid or flexible anchorage line, the CABLOC fall arrester is particularly effective in arresting falls. Thanks to its unique design, it is easy to install and remove. It is particularly light and slides on the cable without obstructing the user. N.B: only operates on installations equipped with an energy absorber at the head of the line.



2.32 Anchorage boom AC340

Mounted at the top and bottom and vertically with respect to the cable, CABLOC lifeline components are connected to it. An essential part of the system, the boom is designed to take up all the forces generated by a fall. Its choice will be governed by the nature of the installation, the support, and the strength of the support. Its design will allow it to be adapted to many profiles.

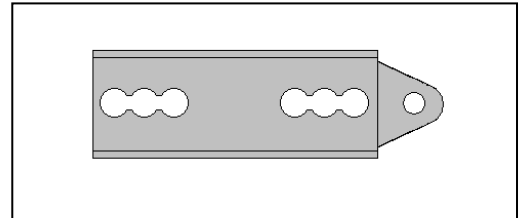

2.33 Energy absorber element AC325

This element has been designed to dissipate the energy generated by a fall and accordingly, to protect the user. It will be mounted at the top of the CABLOC line. The absorber element is a disposable unit. It must be replaced after a fall or when the red tripping indicator is visible.

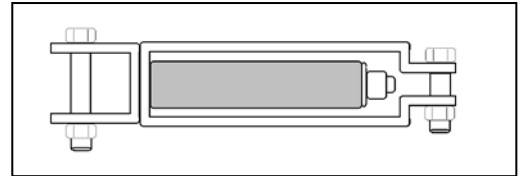

2.34 Yoke / eye tensioner AC330

The cable tensioner is used for adjusting the tension and length of the cable to be required value. The tensioner is designed for the final assembly of the cable (diameter 8 mm). The pre-tension indicator washer on the tensioner instantly allows checking of the correct tension on the safety line cable.

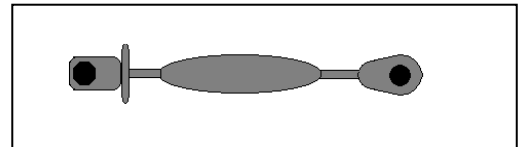

2.35. 38 Cable guide AC320

Suitable for most basic supports Mounted approximately every 10 m, the cable guide is designed to minimize cable floating.

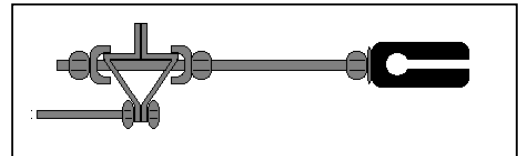

2.36 Cable AC308/I

The \varnothing 8mm (7X19) cable is of stainless steel. Its construction has been designed to guarantee optimum characteristics in terms of strength, flexibility, elasticity and longevity.

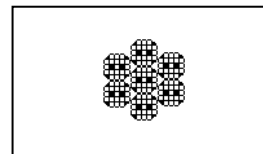

2.37 Warning sign AN126

The warning sign must be set up at current access points to the safety line, as defined by the prevention plan. It is designed to indicate:

- that it is mandatory to wear fall arrest PPE
- the number of persons permitted on the lifeline
- the name of the installer
- the name of the maker
- conformity with the standard

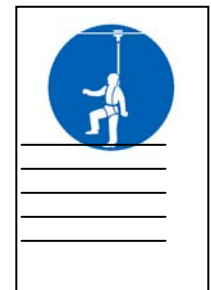

2.38 Automatic lead crimp seal M990059000

The lead crimp is designed to seal the adjustment of the line on completion of the site. It must be installed in the presence of the customer, after the correct operation of the line has been demonstrated. It ensures that the adjustments made by the installer are tamper-proof. Its destruction clears the installer of any liability in the event of an incident.

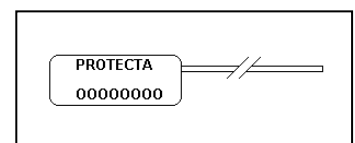

3 Installation procedure

3.1 Installation procedures

3.1.1 DESIGN

Prior study is essential, either by a survey of the premises with necessary measurements taken, or by the supply of precise and contractual drawings. This study will allow determining the layout and utilization modes resulting from the following technical elements: nature of support, centre distances of cable guides, anchorage points etc. This study will take into consideration the design requirements of the standard EN 353/1 or EN 353/2.

3.1.2 ASSEMBLY ON-SITE

Hygiene and safety instructions will be applied in conformity with the current laws and according to the demands applicable to the site. It is highly advisable to establish a coordinated assembly schedule between the installer as per the needs of the customer, to meet the necessary conditions for site operation.

3.1.3 ACCEPTANCE TESTING AFTER ASSEMBLY

Procedure: It is recommended to run a performance test after assembly, in the presence of the users.

On the spot testing:

At the very least, check the strength of the structural anchors at the top end by performing a traction test on each structural anchor loaded at 5kN for 15 seconds. Check the tension of the cable using the pre-tension indicator attached to the tensioner.

Check that the attaching parts have been tightened properly.

Check the operation of the CABLOC fall arrester on the cable by a forward and return movement over the entire length.

After acceptance testing, all the lines in place will be identified by a warning sign AN126 at the entry of the line, lead-sealed to make it tamper-proof.

3.1.4 ACCEPTANCE AND INSPECTION TESTS

Any Approved Organization may inspect the safety lines. In all cases the cost of this operation cannot be charged to Capital Safety Group. In the event of the deterioration of the components during testing, repair and/or replacement of defective parts will be at the expense of the customer in all cases.

Depending on the current standards, a test will be considered conclusive when the load is retained. Deformation of all or part of the equipment will be accepted.

3.1.5 DYNAMIC TESTING

Capital Safety Group advises strongly against dynamic testing for acceptance testing on a CABLOC safety line. This test is destructive.

3.1.6 STATIC TESTING

This test is also destructive and may only be performed on a sample of the installed line consisting of an extra length. The installation of the sample will be at the expense of the customer.

3.2 Particular clauses

3.2.1 SPECIAL ASSEMBLY CONDITIONS

We advise the installer to define the particular clauses inherent to the site with the contractor: weather conditions, production requirements, specific hazards, non-existent access points, special handling and lifting conditions as well as operations on-site, outside of working hours and on holidays.

3.2.2 USE LIMIT

The strength of the line is directly related to the standards of the support and conformity can only be established if the materials forming it are free of any manufacturing defects or reduction in performance resulting from its implementation or use (aging, overload, chemical or climatic attack, etc). The conformity of the CABLOC is only assured if it is used in combination with fall arrest PPE (harness, connector, etc), complying with EC and Australia / New Zealand standards and used in accordance with the manufacturer's recommendations. The parts and accessories, as well as the position and quality of the anchorage points will be strictly as described and recommended in this Technical File. The CABLOC safety lines are designed to protect operators against fall and should never be used as a suspension system.

3.2.3 GUARANTEE

The components of the CABLOC safety line are guaranteed against any manufacturing defects. This guarantee covers the replacement of any parts found to be defective. This guarantee is applicable for 1 year.

3.2.4 GUARANTEE LIMIT

The guarantee does not apply to:

- The supporting materials

- Parts that are damaged by qualification testing, use of the line outside the prescriptions, or in the event of a fall.
- On assembly

3.3 Anchorage boom attachment AC340

The AC340 anchorage booms are designed for installation on **Π O H T I** shaped uprights.

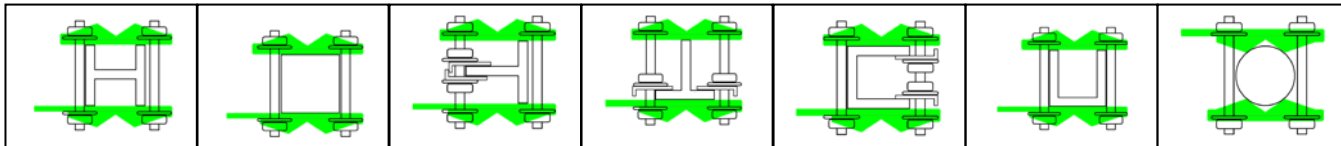

Before each installation, it is essential to validate the strength of the support.

To install an AC340 boom, follow these instructions:

- Position the plate with the flat side against a flat surface or the machined face of the plate against a rounded surface.
- Insert the threaded rod through the hole in the plate as close as possible to the structure.
- Never use the boom in a position where there is a risk of it turning.
- Tighten and bolt down the plates to a minimum torque of 110+/- 20Nm.

If the structure is not symmetrical, of the **Π T** type, it will be necessary to install wedging clips with the necessary bolts to eliminate any risk of the plates moving in case of a fall.

3.4 Installation of an energy absorber AC325

Insert the absorber on the housing side (not on the yoke side), at the end of an anchorage boom, and position the housing attachment hole opposite the hole in the boom.

Insert the M12x30 A4-70 stainless steel bolt in the hole of the absorber housing. Slide the bolt into the hole and tighten the A4 stainless steel locknut until the screw head and nut come up against the absorber housing. The bolt should protrude two threads from the nut.

*Do not tighten until the assembly is locked entirely.

The energy absorber must be free to swivel to guarantee the proper operation of the device. The energy absorber can be installed as desired on the top boom for an installation EN 353 /1 or EN 352/2

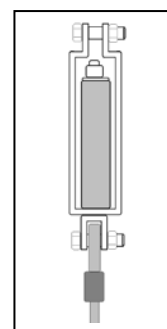
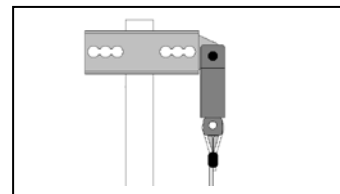
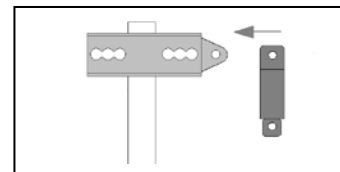

3.5 Installation of cable

The cable can be positioned directly on the boom by means of a stainless steel connector or on the energy absorber.

Connection of cable to energy absorber

To install the cable on the energy absorber:

- undo the yoke bolt, and insert the end of the cable with the eye
- fit the bolt through the yoke and eye and tighten the locknut
- tighten until the assembly is locked entirely.

3.6 Installing the cable guides AC 320

The cable guides are designed to be installed on ladder rungs having the following shapes: **□ ○ ●**

To install AC320 cable guides, follow these instructions:

Position the clamps according to the section of the support

Insert the threaded rod into the holes of the clamps as close as possible to the structure.

Position the rod end perpendicular to the cable.

Run the cable through the rubber cable clamp.

Bolt the clamp and tighten to a capacity of 24 +/- 2Nm.

It is necessary to install the wedging clips with their bolts to eliminate any risk of the cable guides turning.

The cable guides must be not be more than 10 m apart.

3.7 Installation of tensioner

The tensioner is used for EN353/1 installations and is placed at the bottom of the installation between the cable and end boom AC340 or anchorage point AM211

Yoke / yoke tensioner and yoke / eye tensioner

Remove the "split ring" pin from the shaft or nut.
 Pull the shaft out of the yoke.
 Insert the tensioner yoke over the end piece, aligning the attaching holes.
 Insert the shaft from the outside of the part and slide it through the tensioner yoke.
 Assemble the pin or nut back on the shaft.
 Check that none of the parts can come disassembled.
 Adjust the cable tensioner before cable installation
 Retain the tensioner using the incorporated nut.
 Open the tensioner by turning the housing by hand.
 Adjust the opening of the tensioner until the two threaded rods measure at most 60 mm between the housing and the lock nuts used as a stop.
 Cut the cable with a cable cutter, ensuring the length is right and allowing for a cable return length of 15 cm.
 Run the cable through the yoke or eye and then secure it while attaching the cable clamp as indicated in the drawing.
 Check that the assembly is made secure and irremovable.
 Tension the cable manually.
N.B: In some cases, the cable end may be provided with an eye and sleeve. In this situation, use the yoke/yoke tensioner and run the pin of the yoke through the cable eye.

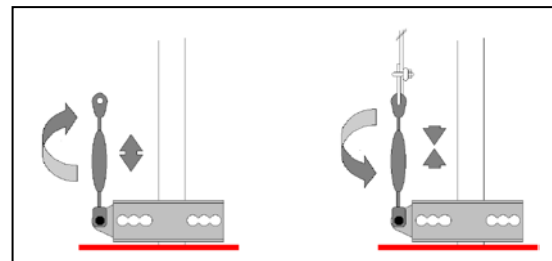
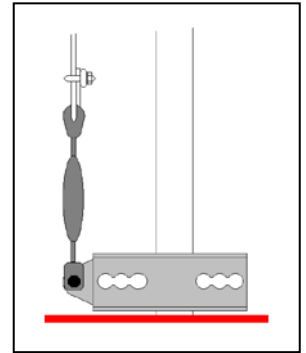

CAUTION: excessive tension would cause the absorber system to trip. The tensioner has a tension checking system (washer marked with a pretension indicator). Choosing the 0.8kN pretension setting is necessary when the washer begins to turn by hand but stays under slight friction. It must never be allowed to turn freely about its axis. In the event of the absorber being damaged, or if the red tripping indicator is visible, the installer is responsible for replacing the energy absorber.

Lock the two locknuts provided on the tensioner housing so that the stem cannot relax.
 Then check the performance of the system over its entire length in the operating configuration.
 The equipment to be used is PPE (Personal Protective Equipment against falls from a height) by Capital Safety Group.
 Only CABLOC AC350 and AC350/4 fall arresters are in conformity with use as per the EC standards.

3.8 Signaling System Identification

The current documents stipulate that device access warning signs are mandatory.
 The installer must set up the AN126 warning sign at the various access points to the device.
 The installer shall mark on this sign, using indelible felt tip pen, or by punched letters and figures:

- 1) The number of persons permitted on the lifeline (Nombre` Personne)
- 2) The name of the installer (must be hand written in visible location)
- 3) The name of the manufacturer (included on data plate)
- 4) The date of installation (Date réception)
- 5) The maintenance dates (Maintenance)

INSTALLATEUR

Tiran d'air

Nombre Personne

Date réception

Maintenance

3.9 Lead sealing

Fig 1: Run the short cable through the tensioner housing

Fig 2: Run the short cable through the anchorage hole.

Fig 3: Insert the short cable in the housing of the lead

Seal through the hole. The small cable shall protrude from the other side

To tighten the lead seal, hold the short cable and push

on of the lead seal. The lead seal housing.

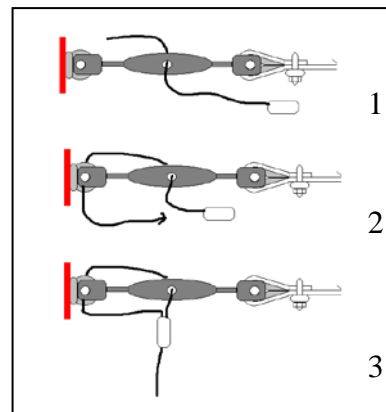

4 Use

The CABLOC safety line by Capital Safety Group is a fall arrest system, a fall arrest device conforming to the standard EN 353/1 or EN 353/2. This device must never be used in any case as a system for suspending people. It is mandatory to use this device with PPE (Personal Protective Equipment against falls from a height) corresponding to the specifications of the EC and Australia / New Zealand standards and equipped with a CABLOC AC350 or AC 350/4 fall arrester guaranteeing trouble-free operation of the system.

Capital Safety Group cannot accept any liability if the instructions for use are not complied with.

5 Maintenance

The CABLOC safety line does not require any particular maintenance.

However, on use:

MANDATORY: After a fall, the CABLOC safety line and the PPE (fall arrester, harness, connector) must be inspected by a competent person.

This visual check consists in analyzing the general good condition of the components (end booms, cable, cable guides, tensioner and absorber, tension and secureness of attachments, etc.)

This equipment is PPE and must be checked prior to and after use; it must also be checked each year by a competent person, qualified by the site owner (company director). The result of the inspection must be registered in the company hygiene and security log.

IN THE EVENT OF A FALL ON A LINE EQUIPPED WITH AN ENERGY ABSORBER, THE PRE-TENSION WASHER WILL NO LONGER TURN AND THE CABLE WILL BE SLACKENED.

6 Limited Lifetime Warranty Statement

Warranty to End User: CAPITAL SAFETY GROUP AUSTRALIA PTY LTD and SKYHOOK AUSTRALIA PTY LTD ("CAPITAL SAFETY") warrants to the original end user ("End User") that its products are free from defects in materials and workmanship under normal use and service. This warranty extends for the lifetime of the product from the date the product is purchased by the End User, in new and unused condition, from a CAPITAL SAFETY authorised distributor. CAPITAL SAFETY'S entire liability to End User and End User's exclusive remedy under this warranty is limited to the repair or replacement in kind of any defective product within its lifetime (as CAPITAL SAFETY in its sole discretion determines and deems appropriate). No oral or written information or advice given by CAPITAL SAFETY, its distributors, directors, officers, agents or employees shall create any different or additional warranties or in any way increase the scope of this warranty. CAPITAL SAFETY will not accept liability for defects that are the result of product abuse, misuse, alteration or modification, or for defects that are due to a failure to install, maintain, or use the product in accordance with the manufacturer's instructions.

CAPITAL SAFETY'S WARRANTY APPLIES ONLY TO THE END USER. THIS WARRANTY IS THE ONLY WARRANTY APPLICABLE TO OUR PRODUCTS AND IS IN LIEU OF ALL OTHER WARRANTIES AND LIABILITIES, EXPRESSED OR IMPLIED. CAPITAL SAFETY EXPRESSLY EXCLUDES AND DISCLAIMS ANY IMPLIED WARRANTIES OF MERCHANTABILITY OR FITNESS FOR A PARTICULAR PURPOSE, AND SHALL NOT BE LIABLE FOR INCIDENTAL, PUNITIVE OR CONSEQUENTIAL DAMAGES OF ANY NATURE, INCLUDING WITHOUT LIMITATION, LOST PROFITS, REVENUES, OR PRODUCTIVITY, OR FOR BODILY INJURY OR DEATH OR LOSS OR DAMAGE TO PROPERTY, UNDER ANY THEORY OF LIABILITY, INCLUDING WITHOUT LIMITATION, CONTRACT, WARRANTY, STRICT LIABILITY, TORT (INCLUDING NEGLIGENCE) OR OTHER LEGAL OR EQUITABLE THEORY.

CABLOC INSPECTION DATASHEET

DESIGNATION		ok	rev	us
TOP BOOM	Check tightness of hardware Check part has not been modified Check for corrosion Check for deformation			
CONNECTOR	Check tightness of attaching ring Check part has not been modified Check for corrosion Check for deformation			
ENERGY ABSORBER	Check tightness of hardware Check part has not been modified Check for corrosion Check for deformation (tripping of fall indicator)			
COPPER SLEEVE LOOP FOR PROTECTA STAINLESS CABLE	Check that sleeve bears PROTECTA marking Check that sleeving is done properly Check that sleeved loop is secured properly to anchor or connector of absorber			
ALUMINUM SLEEVE LOOP FOR PROTECTA GALVANIZED CABLE	Check that sleeve bears PROTECTA marking Check that sleeving is done properly Check that sleeved loop is secured properly to anchor or connector of absorber			
CABLE Ø 8MM	Check that cable is properly tensioned as a function of the tensioner pretension washer or the Protecta International counterweight Check the diameter is 8 mm Check the cable is free of damage Check for corrosion Check for deformation (cable pinching, broken length)			
CABLE GUIDE	Check tightness of hardware Check part has not been modified Check that the rubber part is not broken Check for corrosion Check for deformation			
COUNTERWEIGHT AND CABLE CLAMP	Check tightness of hardware and cable clamps Check part has not been modified Check for corrosion Check that counterweight is 7 kg			
TENSIONER WITH PRETENSION INDICATOR	Check tightness of hardware Check part has not been modified Check for corrosion Check cable tension (tripping of pre-tension indicator) Check for presence of lead seal			
BOTTOM BOOM	Check tightness of hardware Check part has not been modified Check for corrosion Check for deformation			
WARNING SIGN	Check for presence of warning sign Validate verification date			

95 Derby Street Silverwater NSW 2128 Australia
Phone: (02) 8753 7600 **Fax:** (02) 8753 7603
Email: sales@capitalsafety.com.au www.capitalsafety.com.au
 DBI-SALA is a brand of Capital Safety
Call 1800 245 002 (AUS) 0800 212 505 (NZ)

